

LV Motors: Premium Efficiency IE3 Safe Area

Reliable | Energy Efficient



A MOTOR FOR EVERY NEED

BHARAT BIJLEE MOTORS: MILESTONES

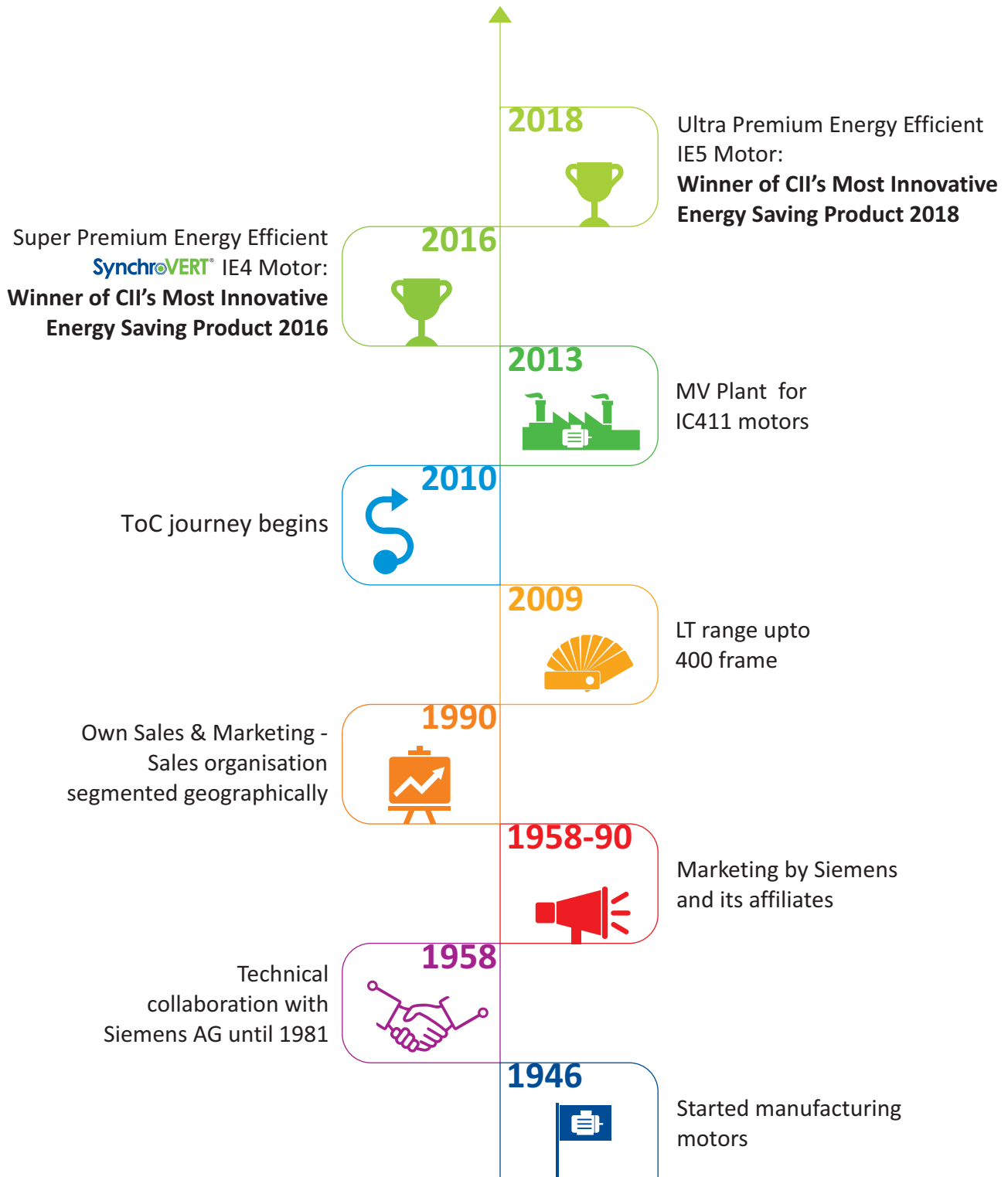

WHY BHARAT BIJLEE?



Preferred brand across multiple sectors like Cement, Construction, Steel, Food & Beverages, Water & Wastewater, and Sugar & Distilleries, to name a few.



Motors suited for all applications i.e. Pumps, Compressors, Fans & Blowers, Conveyors, Lifts, Screen, Vibrators, Centrifuges, Stone Crusher, and many more.



The most suitable solutions for extremely harsh and severe applications.



Customized motors designed and manufactured to suit application-specific needs.



Motors conform to relevant IS/IEC standards.



Annual Production capacity over 3,00,000 motors.



Supply chain based on the concept of Theory of Constraints ensures short lead times, reliable deliveries and superior availability.



Rigorous process control and quality assurance.



Pan India dealer and service network.

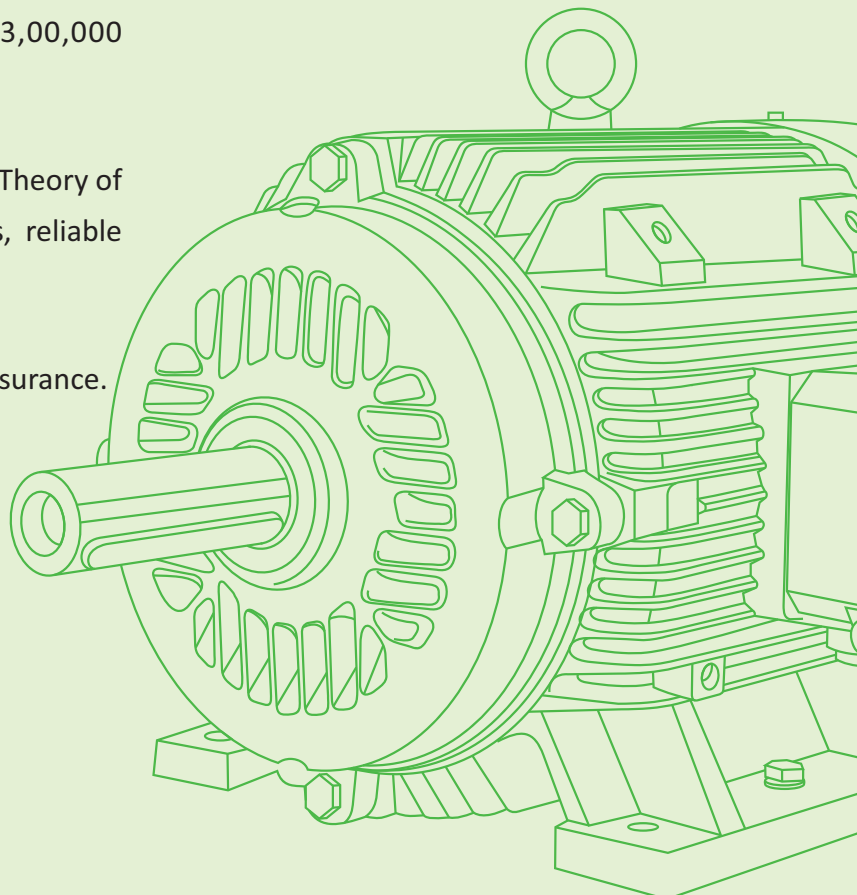

In the past few decades, India has witnessed significant economic growth due to liberalization and industrialization. The contribution of industries and services towards the Indian economy (GDP) has been increasing over a period of time. However, this is accompanied by an increase in energy demand, most of which is obtained through conventional sources of energy, which today contributes to 82% of the total power produced in our country. This ever-increasing demand leads to increase in all other aspects associated with it, which include air pollution and emission of greenhouse gases due to burning of fossil fuels (a non-renewable source of energy). In view of this situation, it becomes imperative to explore new and viable solutions to save energy. These include usage of energy-efficient equipment, especially in industries, as it accounts for over half the consumption of electricity, 60-70% of which is utilized by electric motors.

The operating cost of an electric motor is about 95% of the total cost incurred during its lifecycle, which that ranges between 15 to 20

years. Organizations that have proactively invested in energy-efficient motors have reaped the benefits like of better output, increased cost savings, or both.

Bharat Bijlee has been a fore runner in energy efficiency. With a strong in-house design team, indigenous and state-of-the-art manufacturing facility equipped with a SCADA controlled test bed, we have successfully developed a wide range of premium efficiency IE3 series motors. Over the years, Bharat Bijlee has gained the trust of its customers and with the ability to deliver beyond customers' expectations, this trust has only grown stronger. Known for its product and service quality, there is more to what makes Bharat Bijlee a preferred brand across the country.

Our IE3 motors have been successfully working across all sectors and in all possible applications over the years, and have exceeded expectations of performance and reliability. Owing to this, Bharat Bijlee is one of the most trusted brands in the country today.



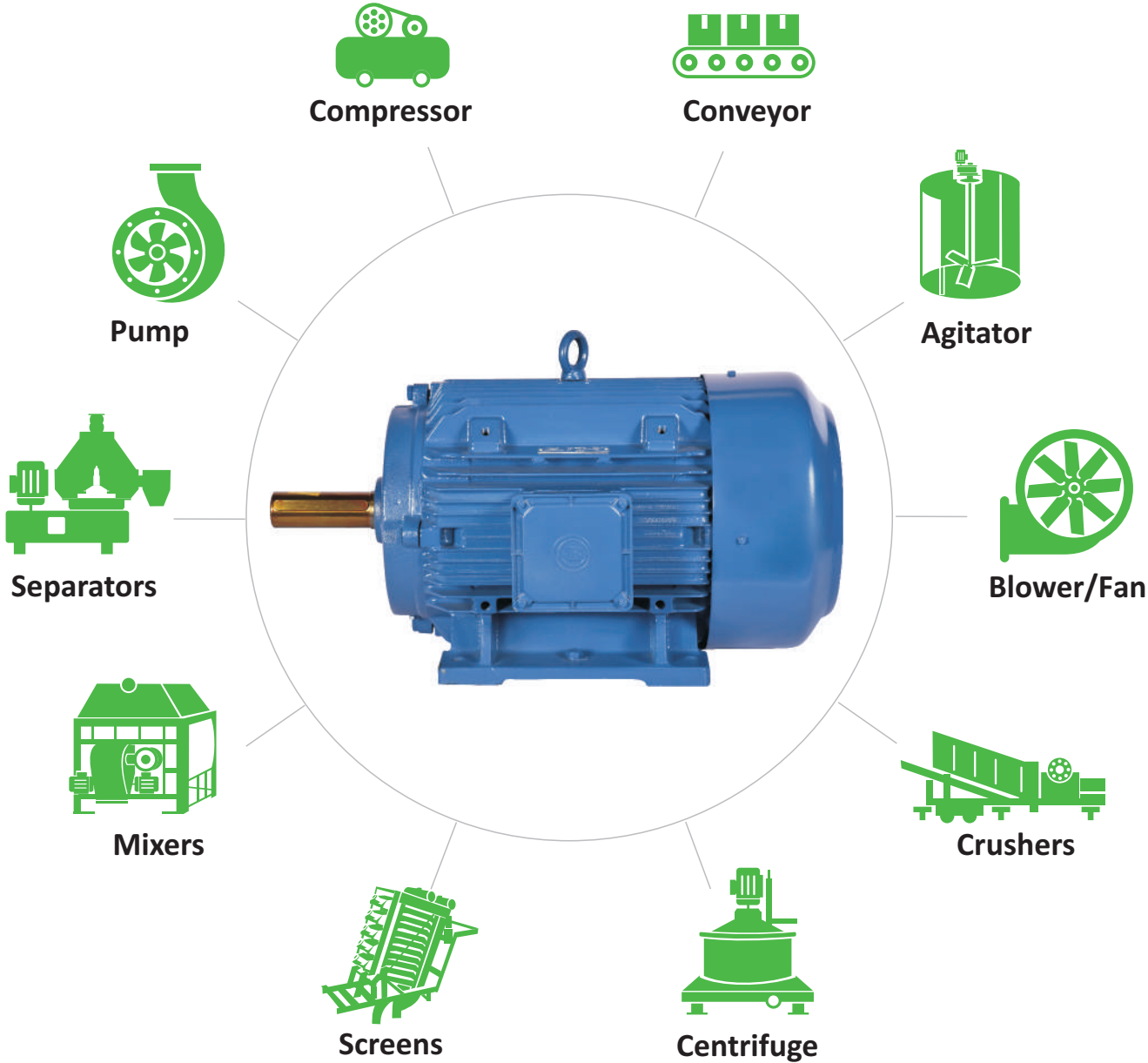

A MOTOR FOR EVERY NEED

MAJOR APPLICATIONS OF BHARAT BIJLEE MOTORS ACROSS ALL SECTORS



REFERENCE STANDARDS

IS/IEC 60034-1	Three Phase Induction Motor specifications (“Rotating Electrical Machines - Part 1: Rating & Performance”)
IS : 900	Code of practice for installation & maintenance of Induction Motors
IS: 1231	Dimensions of foot mounted A.C Induction Motors
IS: 2223	Dimensions of flange mounted A.C Induction Motors
IS: 4029	Guide for testing Three Phase Induction Motors (For Standard TEFC SCR Motors)
IS: 4889	Methods of determination of efficiency of Rotating Electrical Machines (For Standard TEFC SCR Motors)
IS/IEC 60034-5	Degree of protection provided by the integral design of Rotating Electrical Machines (IP Code Classification)
IS: 6362/IEC 60034-6	Designation of method of cooling for Rotating Electrical Machines / Method of cooling (IC Code)
IS:12065/IEC 60034-9	Permissible limits of noise level for Rotating Electric Machines
IS : 12075	Mechanical Vibration of Rotating Electrical Machines
IS : 12615	Energy-Efficient Induction Motors Three Phase Squirrel Cage
IEC 60034-30	Rotating Electrical Machines - Efficiency classes of line operated AC Motors (IE Code)
IEC 60072-1	Dimension & Output rating of Rotating Electrical Machines
IS:15999 (Part 2/Sec 1)	Standard Methods for determining Losses and Efficiency from Tests (For IE Series Motors)

		3 Ph.Sq.Cage Ind.Motor 3 CM/L 7800028518		IS:12615 	
No. L1502874		3H22S4B3CT000		225S	
kW/HP 37/50		In.Cl. F / B Rise		p.f. 0.84	
V Range	V	A	Eff% 93.9%	Duty S1	
	415	65.3	Amb 50°C	IP 55	
	Hz 50 ±5%		RPM 1482	420 Kg	
Grease: LGMT3/K3K-30		6313 C3		6213 C3	
Regreasing Hrs: 4000, 20g/BRG		IS/IEC60034-1			
Works: No.2, MIDC, Airoli, Navi Mumbai, India					









SCADA Test Facility







MOUNTING ARRANGEMENT

Base refers to baseplate, foundation, slide rails, pedestal, etc.

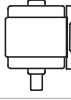



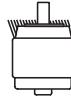

Horizontal Mounting

Symbol	Schematic Diagram	Frame	Mounting
B3		With feet	Mounted on base
B5		Without feet	Mounted on Type B flange with shaft extension at flange end
B35		With feet	Mounted on base with feet, and on Type B flange with shaft extension at flange end
B6		With feet	Mounted on base to the wall; feet towards the left when viewed from DE side
B7		With feet	Mounted on base to the wall; feet towards the right when viewed from DE side
B8		With feet	Mounted on base to the ceiling; feet at the top
B14		Without feet	Mounted on Type C flange with shaft extension at flange end

Vertical Mounting

Symbol	Schematic Diagram	Frame	Mounting
V5		With feet	Mounted on base to the wall; shaft downwards
V6		With feet	Mounted on base to the wall; shaft upwards
V1		Without feet	Mounted on Type B flange with shaft extension at flange end; shaft downwards
V3		Without feet	Mounted on Type B flange with shaft extension at flange end; shaft upwards
V18		Without feet	Mounted on Type C flange with shaft extension at flange end; shaft downwards
V19		Without feet	Mounted on Type C flange with shaft extension at flange end; shaft upwards

ADVANTAGES OF BHARAT BIJLEE PREMIUM EFFICIENCY IE3 MOTOR

 Higher efficiency	 Optimized ventilation system for cooler operation and reduced noise
 Reduced lifecycle cost	 Highly reliable under most demanding conditions
 Short payback period	 Carbon credits
 Inverter grade winding	 A sustainable future

The operating cost of a motor accounts for major expenditure during its lifecycle. Opting for premium efficient motors allows the user to realize energy cost savings in a reasonably short span of time.



Comparison of IE2 v/s IE3 motor for 2.2 kW and 22 kW is depicted in the table below, clearly showing:

 Annual energy saving for one motor

 Payback period

 Total savings over the lifespan of one motor

Aspect	Energy Savings Observed in 2.2 kW / 4Pole motor		Energy Savings Observed in 22 kW / 4Pole motor	
	IE3	IE2	IE3	IE2
kW Rating	2.2	2.2	22	22
Purchase Cost of Motor (INR)	11403	9961	68488	60711
Motor Efficiency	86.7%	84.3%	93.0%	91.6%
Per Hour kW Consumption	2.54	2.61	23.66	24.02
Annual running Hours: 300 Days X 16 Hrs	4800	4800	4800	4800
Power Consumption/Annum (kW)	12180	12527	113548	115284
Average energy cost (INR/kWH)	7	7	7	7
Average energy cost /annum (INR)	85260	87687	794839	806987
Annual Saving when IE3 motor is used (INR)	2427		12148	
Motor Cost Differential (INR)	1442		7777	
Payback Period for differential amount (Months)	7		8	
Saving Over 20 year Life (INR)	48546		242964	

For 20 motors each of 2.2kW and 22 kW, the savings shall be Rs.10 and 50 lakhs respectively, thus totaling to 60 lakhs during the motors' lifespan of 20 years.

GENERAL TECHNICAL SPECIFICATIONS

Range

- **Series:** 3 Phase Squirrel Cage Induction, IE3 Safe Area Motors
- **kW Rating:** 0.12 to 355
- **Frame:** 63 to 355
- **Polarity:** 2, 4, 6, 8



Standard Feature	Optional Feature
Voltage: 415V	Any other voltage on request
Frequency: 50 Hz	60 Hz
IP55	IP56, IP65, IP66
B3 Mounting	B5, B35, B14 (upto 132 Frame)
Ambient: 50°C	Any other on request
Altitude: up to 1000 m above mean sea level	Motors for higher altitudes on request
TB Position : Top	Any other on request
Aluminium Construction: 63 to 71 frame, 90 to 132 frame Cast Iron Construction: 80 Frame, 160 Frame & Above	Cast Iron construction: 90 to 132 Frame
Insulation: Class F	Insulation: Class H
IC411: Totally Enclosed Fan Cooled	IC410: Natural Ventilation IC416: Forced Cooling for 132 Frame & above
Sealed Bearing: upto 200 Frame Online Greasing Arrangement: 225 Frame & Above	Online Greasing Arrangement: 160 to 200 Frame
Paint Shade: Acrylic base, RAL5000	Any other shade or material on request
Fan Cover: Steel	
Thermal Protection in DCCA** Motors: 3 nos. simplex RTD	Simplex & duplex RTD: 250 Frame & Above BTD: 250 Frame & above Thermister: 80 Frame & Above
Space Heater for DCCA Motors	Space Heater: 90 Frame & Above
Inverter Duty Application for all frames	
Packing: Thermocol / Corrugated Boxes: Upto 132 Frame Packing: Wooden Packing Boxes: 160 Frame & Above	Wooden Pallets Sea Worthy / Export Packing Case
For standard bearings, kindly refer to the bearing chart	Insulated Bearing: 160 Frame & Above / Hybrid Bearing: 132 to 225 Frame Cylindrical Roller Bearing on DE Side: 160 Frame & Above

Our other optional features:

- Space heater for 90 frame and above.
- Non standard shaft material, diameter and extension.
- Front bearing locking arrangement.
- SS Hardware, canopy, water flinger, non standard paint & paint shade, cable gland.
- Provision for hollow shaft encoder mounting.
- High temperature grease.
- Reduced & special grades of vibration as per IS 12075 can be provided on request.

** Please confirm with our nearest sales office.

RE-RATING FACTORS APPLICABLE UNDER DIFFERENT CONDITIONS OF SUPPLY VOLTAGE, FREQUENCY, AMBIENT AND ALTITUDE

I. Variation in Supply Voltage and Frequency

Voltage Variation %	Frequency Variation %	Combined Voltage & Frequency %	Permissible Output as % of Rated Value
± 10	± 5	± 10	100
± 12.5	± 5	± 12.5	95
± 15	± 5	± 15	90

II. Variation in Ambient

Ambient Temperature (°C)	Permissible Output as % of Rated Value
< 30	107
30 to 45	103
50	100
55	96
60	92

III. Variation in Altitude

Altitude Above Mean Sea Level (m)	Permissible Output as % of Rated Value
1000	100
1500	97
2000	94
2500	90
3000	86
3500	82
4000	77

Method of Starting:

kW Rating	Method of Starting	No. of Leads
Upto & including 1.5kW	DOL	6
Above 1.5kW	DOL or Star / Delta	6

Number of Consecutive Starts:

For continuous (S1) duty motors wherein load $GD^2 \leq$ Motor GD^2 , the motors can safely withstand 3 consecutive starts from cold condition and 2 consecutive starts from hot condition.

Starting Current Measurement of Bharat Bijlee Motors:

Induction motor starting current is generally 6 to 7 times the rated current of the motor. Starting current measurement may be carried out at reduced voltage due to capacity constraint and then extrapolated to the rated voltage. At Bharat Bijlee, the starting current measurement is done at reduced voltage as per the table below.

kW Range	Measurement at % of voltage to rated voltage
0.12kW to 90kW	70%
90kW to 200kW	60%
200kW to 355kW	35%
355kW to 560kW	25%
560kW and above (with rated voltage 690V or higher)	25%

Bearing Chart

Frame Size	Bearing Nos.	
	D.E.	N.D.E.
63	6201 2Z	6201 2Z
71	6202 2Z	6202 2Z
80	6204 2Z	6204 2Z
90S & L	6205 2Z	6205 2Z
100L	6206 2Z	6205 2Z
112M	6206 2Z	6205 2Z
132S / M	6208 2Z	6208 2Z
160M/L	6309 2Z	6209 2Z
180M/L	6310 2Z	6210 2Z
200L	6312 2Z	6212 2Z
225S/M	6313	6213
250M	6315	6215
280S/M (2 Pole)	6316	6316
280S/M (4,6,8 Pole)	6317	6316
315S/M & L	6319	6319
355L	6322	6322

LV MOTORS: IE3 SAFE AREA

Performance Data : IE3 Efficiency Series for Safe Area Application

Applicable standard for testing & efficiency determination : IS15999

Voltage: 415V +/- 10%

Frequency: 50Hz +/- 5%

Combined Variation: +/- 10%

Ambient: 50°C

Duty: S1 (Continuous)

3000 rpm (2 Pole)

Insulation: Class F
Temperature Rise: Class B
Protection: IP55

Rated Output		Frame size	Type Reference	Operating characteristics at rated output						With DOL starting				Rotor GD ² kgm ²	Net Weight B3 constr. kg		
kW	HP			Rated Speed RPM	Rated Current Amps.	Rated Torque kg-m	Power Factor			% Efficiency	Starting Current to Rated Current Ratio	Starting Torque to Rated Torque Ratio	Pullout Torque to Rated Torque Ratio				
			B3 construction			FL	3/4L	1/2L	FL	3/4L	1/2L	1/2L					
0.18	0.25	63	3H063213AT000	2700	0.49	0.065	0.78	0.70	0.60	65.9	60.0	60.0	3.5	2.5	2.7	0.0005	4.5
0.25	0.35	63	3H063233AT000	2700	0.61	0.090	0.82	0.70	0.60	69.7	64.0	64.0	3.5	2.5	2.7	0.0006	5
0.37	0.50	71	3H071233AT000	2860	0.91	0.126	0.77	0.65	0.55	73.8	67.0	67.0	5.5	2.9	3.2	0.0016	7.7
0.55	0.75	71	3H071253AT000	2840	1.28	0.189	0.77	0.70	0.56	77.8	74.5	74.5	5.0	2.7	3.0	0.0018	9
0.75	1.0	80	3H0802B3CT000	2840	1.54	0.26	0.84	0.80	0.68	80.7	78.0	78.0	6.0	3.0	3.5	0.0091	17
1.1	1.5	80	3H0802E3CT000	2840	2.20	0.38	0.84	0.80	0.68	82.7	80.0	80.0	6.0	3.0	3.5	0.0113	18
1.5	2.0	90S	3H09S2B3AT000	2850	2.88	0.51	0.86	0.81	0.72	84.2	84.2	84.2	6.5	2.75	3.0	0.0066	18
2.2	3.0	90L	3H09L2E3AT000	2850	4.14	0.75	0.86	0.80	0.71	85.9	85.5	85.5	6.5	3.0	3.3	0.0084	21
3.7	5.0	100L	3H10L2B3AT000	2890	6.74	1.25	0.87	0.82	0.73	87.8	87.3	87.3	7.0	3.0	3.1	0.0158	26
5.5	7.5	132S	3H13S2C3AT000	2935	9.53	1.83	0.90	0.87	0.81	89.2	89.2	89.2	7.0	2.3	3.0	0.0878	62
7.5	10	132S	3H13S2H3AT000	2935	12.9	2.49	0.90	0.87	0.81	90.1	88.7	88.7	7.0	2.3	3.0	0.0936	65
9.3	12.5	160M	3H16M2B3CT000	2950	16.6	3.07	0.86	0.83	0.76	90.7	90.3	90.3	6.5	2.3	2.8	0.151	101
11	15	160M	3H16M2E3CT000	2950	19.3	3.63	0.87	0.83	0.76	91.2	89.2	89.2	7.0	2.5	3.0	0.173	109
15	20	160M	3H16M2H3CT000	2945	26.1	4.96	0.87	0.84	0.77	91.9	90.0	90.0	6.5	2.3	2.8	0.217	126
18.5	25	160L	3H16L2M3CT000	2945	31.3	6.12	0.89	0.86	0.79	92.4	90.8	90.8	6.5	2.3	2.8	0.258	144
22	30	180M	3H18M2B3CT000	2950	37.5	7.26	0.88	0.84	0.78	92.7	91.0	91.0	7.0	2.7	3.0	0.336	188
30	40	200L	3H20L2B3CT000	2970	51.4	9.84	0.87	0.85	0.79	93.3	91.5	91.5	6.5	2.2	2.8	0.910	306
37	50	200L	3H20L2E3CT000	2970	63.1	12.1	0.87	0.85	0.79	93.7	92.0	92.0	6.5	2.2	2.8	1.13	315
45	60	225M	3H22M2B3CT000	2965	75.7	14.8	0.88	0.86	0.82	94.0	93.0	93.0	6.6	2.1	2.7	1.19	395
55	75	250M	3H25M2E3CT000	2970	91.2	18.0	0.89	0.86	0.80	94.3	93.0	93.0	6.5	2.4	2.8	2.60	550
75	100	280S	3H28S2E3CT000	2970	121	24.6	0.91	0.89	0.86	94.7	92.7	92.7	7.0	2.0	2.7	3.08	675
90	120	280M	3H28M2H3CT000	2970	145	29.5	0.91	0.89	0.86	95.0	93.0	93.0	7.0	2.0	2.7	3.69	760
110	150	315S	3H31S2E3CT000	2982	179	35.9	0.90	0.86	0.80	95.2	94.6	94.6	7.0	2.2	2.5	5.00	940
132	180	315L	3H31L2H3CT000	2982	214	43.1	0.90	0.86	0.80	95.4	93.2	93.2	7.0	2.2	2.5	6.20	1100
150	200	315L	3H31L2A3CT000	2982	246	49.0	0.89	0.85	0.80	95.5	93.5	93.5	7.0	2.2	2.5	7.70	1390
160	215	315L	3H31L2M3CT000	2982	262	52.3	0.89	0.85	0.80	95.6	93.6	93.6	7.0	2.2	2.5	7.70	1390
180	240	355L	3H35L2A3CT000	2987	284	58.7	0.92	0.89	0.86	95.7	93.7	93.7	7.0	1.8	2.4	12.0	1680
200	270	355L	3H35L2B3CT000	2988	316	65.2	0.92	0.89	0.84	95.8	93.8	93.8	7.0	2.0	2.5	12.0	1680
225	335	355L	3H35L2C3CT000	2987	355	73.4	0.92	0.89	0.84	95.8	93.8	93.8	6.5	1.8	2.4	12.0	1680
250	335	355L	3H35L2E3CT000	2988	395	81.5	0.92	0.90	0.86	95.8	93.8	93.8	7.0	2.0	2.5	14.7	1870
280	375	355L	3H35L2G3CT000	2987	442	91.0	0.92	0.90	0.86	95.8	93.8	93.8	6.5	1.8	2.4	18.9	2140

Note: All performance values are subject to tolerance as per IS/IEC 60034-1

LV MOTORS: IE3 SAFE AREA

Performance Data : IE3 Efficiency Series for Safe Area Application

Applicable standard for testing & efficiency determination : IS15999

Voltage: 415V +/- 10%

Frequency: 50Hz +/- 5%

Combined Variation: +/- 10%

Ambient: 50°C

Duty: S1 (Continuous)

1500 rpm (4 Pole)

Insulation: Class F

Temperature Rise: Class B

Protection: IP55

Rated Output		Frame size	Type Reference	Operating characteristics at rated output				With DOL starting				Rotor GD ² kgm ²	Net Weight B3 constr.				
kW	HP			Rated Speed RPM	Rated Current Amps.	Rated Torque kg-m	Power Factor			% Efficiency	Starting Current to Rated Current Ratio			Starting Torque to Rated Torque Ratio	Pullout Torque to Rated Torque Ratio		
			B3 construction	FL	3/4L	1/2L	FL	3/4L	1/2L	FL	3/4L	1/2L					
0.25	0.35	71	3H071453AT000	0.71	0.63	0.52	0.71	0.63	0.52	73.5	73.5	72.0	4.0	2.0	2.5	0.0031	8
0.37	0.5	71	3H071463AT000	0.69	0.61	0.50	0.69	0.61	0.50	77.3	77.3	74.0	4.5	2.5	2.8	0.0038	10
0.55	0.75	80	3H0804B3CT000	0.78	0.74	0.60	0.78	0.74	0.60	80.8	80.8	79.8	5.0	2.2	2.8	0.0110	17
0.75	1.0	80	3H0804E3CT000	0.78	0.74	0.60	0.78	0.74	0.60	82.5	82.5	82.5	5.0	2.6	2.8	0.0150	19
1.1	1.5	90S	3H09S4B3AT000	0.78	0.70	0.55	0.78	0.70	0.55	84.1	84.1	82.5	5.5	2.5	2.7	0.0121	17
1.5	2.0	90L	3H09L4E3AT000	0.78	0.70	0.55	0.78	0.70	0.55	85.3	85.3	84.5	6.0	2.5	2.7	0.0149	20
2.2	3.0	100L	3H10L4B3AT000	0.78	0.72	0.60	0.78	0.72	0.60	86.7	86.7	85.8	6.0	2.5	3.0	0.0245	26
3.7	5.0	112M	3H11M4B3AT000	0.79	0.74	0.60	0.79	0.74	0.60	88.4	88.4	86.5	6.5	3.0	3.5	0.0588	37
5.5	7.5	132S	3H13S4C3AT000	0.83	0.78	0.66	0.83	0.78	0.66	89.6	89.6	88.4	6.5	2.5	3.0	0.117	52
7.5	10	132M	3H13M4H3AT000	0.83	0.78	0.66	0.83	0.78	0.66	90.4	90.4	89.4	6.5	2.5	3.3	0.157	70
9.3	12.5	160M	3H16M4E3CT000	0.82	0.77	0.66	0.82	0.77	0.66	91.0	91.0	90.4	6.5	2.1	2.5	0.212	105
11	15	160M	3H16M4H3CT000	0.82	0.77	0.66	0.82	0.77	0.66	91.4	91.4	90.8	6.5	2.1	2.5	0.235	118
15	20	160L	3H16L4M3CT000	0.83	0.78	0.68	0.83	0.78	0.68	92.1	92.1	91.6	6.5	2.2	2.7	0.306	136
18.5	25	180M	3H18M4B3CT000	0.84	0.80	0.70	0.84	0.80	0.70	92.6	92.6	91.5	6.5	2.6	2.9	0.550	188
22	30	180L	3H18L4E3CT000	0.84	0.80	0.70	0.84	0.80	0.70	93.0	93.0	92.0	6.5	2.6	2.9	0.635	209
30	40	200L	3H20L4B3CT000	0.87	0.84	0.77	0.87	0.84	0.77	93.6	93.6	91.5	6.5	2.6	3.0	1.138	295
37	50	225S	3H22S4B3CT000	0.84	0.80	0.70	0.84	0.80	0.70	93.9	93.9	93.4	6.5	2.5	2.6	1.79	368
45	60	225M	3H22M4E3CT000	0.85	0.81	0.72	0.85	0.81	0.72	94.2	94.2	93.5	6.5	2.6	2.8	2.03	396
55	75	250M	3H25M4B3CT000	0.84	0.80	0.72	0.84	0.80	0.72	94.6	94.6	93.8	6.0	2.0	2.6	3.06	500
75	100	280S	3H28S4B3CT000X	0.84	0.80	0.72	0.84	0.80	0.72	95.0	95.0	94.2	6.5	2.5	3.0	5.53	680
90	120	280M	3H28M4H3CT000X	0.85	0.82	0.74	0.85	0.82	0.74	95.2	95.2	94.5	6.5	2.5	3.0	6.36	735
110	150	315S	3H31S4G3CT000	0.85	0.82	0.74	0.85	0.82	0.74	95.4	95.4	93.9	6.8	2.5	3.0	11.7	965
132	180	315M	3H31M4K3CT000	0.85	0.82	0.74	0.85	0.82	0.74	95.6	95.6	94.1	6.8	2.5	3.0	14.0	1115
160	215	315L	3H31L4P3CT000	0.84	0.80	0.72	0.84	0.80	0.72	95.8	95.8	94.5	6.6	2.5	3.0	15.6	1225
180	240	315L	3H31L4T3CT000	0.84	0.80	0.72	0.84	0.80	0.72	95.9	95.9	94.6	6.6	2.7	3.0	17.8	1290
200	270	315L	3H31L4W3CT000	0.84	0.80	0.72	0.84	0.80	0.72	96.0	96.0	95.0	6.6	2.7	3.0	17.8	1290
225	300	355L	3H35L4B3CT000	0.87	0.83	0.72	0.87	0.83	0.72	96.0	96.0	95.0	6.0	1.7	2.4	23.3	1680
250	335	355L	3H35L4E3CT000	0.87	0.83	0.72	0.87	0.83	0.72	96.0	96.0	95.0	6.5	1.8	2.4	32.7	1855
315	422	355L	3H35L4H3CT000	0.87	0.83	0.72	0.87	0.83	0.72	96.0	96.0	95.0	6.5	1.8	2.4	31.9	2159

Note: All performance values are subject to tolerance as per IS/IEC 60034-1

LV MOTORS: IE3 SAFE AREA

Performance Data: IE3 Efficiency Series for Safe Area Application

Applicable standard for testing & efficiency determination : IS15999
 Voltage: 415V +/- 10%
 Frequency: 50Hz +/- 5%
 Combined Variation: +/- 10%

Ambient: 50°C
 Duty: S1 (Continuous)
 1000 rpm (6 Pole)

Insulation: Class F
 Temperature Rise: Class B
 Protection: IP55

Rated Output		Frame size	Type Reference	Operating characteristics at rated output						With DOL starting			Rotor GD ² kgm ²	Net Weight B3 constr. kg				
kW	HP			Rated Speed RPM	Rated Current Amps.	Rated Torque kg-m	Power Factor			% Efficiency	Starting Current to Rated Current Ratio	Starting Torque to Rated Torque Ratio			Pullout Torque to Rated Torque Ratio			
			B3 construction		FL	3/4L	1/2L	FL	3/4L	1/2L	FL	3/4L	1/2L					
0.75	1.0	90S	3H09SG83AT000	925	1.84	0.79	0.72	0.62	0.52	0.52	78.9	78.9	78.6	4.0	2.1	2.5	0.0143	17
1.1	1.5	90L	3H09L6E3AT000	920	2.62	1.16	0.72	0.62	0.52	0.52	81.0	81.0	80.0	4.0	2.0	2.5	0.0181	20
1.5	2.0	100L	3H10L6B3AT000	935	3.51	1.56	0.72	0.62	0.54	0.54	82.5	82.5	81.0	4.5	2.3	2.5	0.0275	24
2.2	3.0	112M	3H11M6B3AT000	960	4.84	2.23	0.75	0.68	0.55	0.55	84.3	84.3	81.0	6.0	2.3	2.5	0.0691	36
3.7	5.0	132S	3H13SGC3AT000	960	7.83	3.75	0.76	0.70	0.58	0.58	86.5	86.5	86.0	5.5	2.2	2.6	0.121	50
5.5	7.5	132M	3H13M6H3AT000	965	11.3	5.55	0.77	0.70	0.60	0.60	88.0	88.0	87.5	5.5	2.2	2.6	0.180	70
7.5	10	160M	3H16M6B3CT000	970	15.2	7.53	0.77	0.72	0.61	0.61	89.1	89.1	88.5	6.0	2.0	2.6	0.275	106
9.3	12.5	160L	3H16L6E3CT000	970	18.7	9.34	0.77	0.72	0.61	0.61	89.8	89.8	89.0	6.0	2.0	2.6	0.332	122
11	15	160L	3H16L6H3CT000	970	22.0	11.0	0.77	0.72	0.61	0.61	90.3	90.3	89.2	6.0	2.0	2.6	0.390	134
15	20	180L	3H18L6B3CT000	977	27.6	15.0	0.83	0.78	0.72	0.72	91.2	91.2	91.2	5.5	2.5	3.0	0.886	205
18.5	25	200L	3H20L6B3CT000	977	32.3	18.4	0.87	0.83	0.75	0.75	91.7	91.7	91.5	6.5	2.6	3.2	1.81	295
22	30	200L	3H20L6E3CT000	977	37.7	21.9	0.88	0.85	0.76	0.76	92.2	92.2	92.2	6.5	2.6	3.2	2.10	302
30	40	225M	3H22M6B3CT000	984	51.1	29.7	0.88	0.84	0.77	0.77	92.9	92.9	92.6	6.5	3.0	3.5	2.85	387
37	50	250M	3H25M6B3CT000	982	62.0	36.7	0.89	0.86	0.79	0.79	93.3	93.3	92.8	6.5	2.8	3.2	3.72	528
45	60	280S	3H28SG83CT000	984	78.6	44.5	0.85	0.80	0.72	0.72	93.7	93.7	92.9	6.0	2.6	3.2	5.11	573
55	75	280M	3H28M6E3CT000	984	93.5	54.4	0.87	0.84	0.78	0.78	94.1	94.1	93.2	6.0	2.6	3.2	6.16	620
75	100	315S	3H31SG83CT000	992	130	73.6	0.85	0.82	0.72	0.72	94.6	94.6	93.6	6.0	2.5	3.0	10.7	830
90	120	315M	3H31M6E3CT000	992	155	88.4	0.85	0.82	0.72	0.72	94.9	94.9	93.9	6.0	2.5	3.0	12.4	912
110	150	315M	3H31M6H3CT000	992	189	108	0.85	0.82	0.72	0.72	95.1	95.1	94.2	6.0	2.5	3.0	15.5	1010
132	180	315L	3H31L6M3CT000	992	229	130	0.84	0.80	0.72	0.72	95.4	95.4	94.4	6.0	2.5	3.0	18.0	1175
160	215	355L	3H35L6B3CT000	990	277	157	0.84	0.81	0.71	0.71	95.6	95.6	93.0	6.0	2.0	2.5	28.7	1670
180	240	355L	3H35L6C3CT000	990	319	177	0.82	0.78	0.66	0.66	95.7	95.7	94.0	6.0	2.0	2.5	28.7	1670
200	270	355L	3H35L6E3CT000	991	346	197	0.84	0.80	0.70	0.70	95.8	95.8	94.1	6.0	2.0	2.5	35.5	1780
250	335	355L	3H35L643CT000	991	432	246	0.84	0.80	0.70	0.70	95.8	95.8	94.1	6.0	2.0	2.5	40.1	2154

Note: All performance values are subject to tolerance as per IS/IEC 60034-1

LV MOTORS: IE3 SAFE AREA



Performance Data: IE3 Efficiency Series for Safe Area Application

Applicable standard for testing & efficiency determination : IS15999
 Voltage: 415V +/- 10%
 Frequency : 50Hz +/- 5%
 Combined Variation: +/- 10%

Ambient: 50°C
 Duty: S1 (Continuous)
 750 rpm (8 Pole)

Insulation: Class F
 Temperature Rise: Class B
 Protection: IP55

Rated Output		Frame size	Type Reference	Operating characteristics at rated output				With DOL starting				Rotor GD ² kgm ²	Net Weight B3 constr. kg					
kW	HP			Rated Speed RPM	Rated Current Amps.	Rated Torque kg-m	Power Factor			% Efficiency	Starting Current Ratio			Starting Torque Ratio	Pullout Torque Ratio			
			B3 construction		FL	3/4L	1/2L	FL	3/4L	1/2L	FL	3/4L	1/2L					
0.12	0.16	71	3H071833AT000	640	0.60	0.18	0.55	0.50	0.40	0.40	50.7	50.7	45.0	2.2	1.7	2.1	0.0033	7
0.37	0.5	90S	3H09S853AT000	700	1.10	0.51	0.68	0.58	0.45	0.45	69.3	69.3	65.0	3.5	1.8	2.0	0.0130	14
0.55	0.75	90L	3H09L863AT000	690	1.54	0.78	0.68	0.58	0.45	0.45	73.0	73.0	68.0	3.5	1.8	2.0	0.0170	15
0.75	1	100L	3H10L833AT000	695	2.00	1.05	0.70	0.60	0.50	0.50	75.0	75.0	73.0	3.8	1.9	2.3	0.0270	20
1.1	1.5	100L	3H10L853AT000	695	2.80	1.54	0.70	0.60	0.50	0.50	77.7	77.7	75.0	3.8	1.9	2.3	0.0340	23
1.5	2	112M	3H11M833AT000	700	3.64	2.09	0.72	0.64	0.52	0.52	79.7	79.7	78.0	3.8	1.7	2.2	0.0590	28
2.2	3	132S	3H13S883AT000	710	5.1	3.02	0.74	0.66	0.55	0.55	81.9	81.9	80.0	3.8	1.7	2.2	0.0910	41
3.7	5	160M	3H16M823CT000	715	8.1	5.04	0.75	0.70	0.58	0.58	84.5	84.5	83.0	4.8	1.7	2.2	0.219	91
5.5	7.5	160M	3H16M843CT000	715	11.8	7.49	0.75	0.70	0.58	0.58	86.2	86.2	85.0	4.8	1.8	2.3	0.350	111
7.5	10	160L	3H16L883CT000	715	15.9	10.2	0.75	0.70	0.58	0.58	87.3	87.3	86.0	4.8	1.8	2.3	0.418	126
9.3	12.5	180M	3H18M873CT000	725	19.3	12.5	0.76	0.70	0.60	0.60	88.1	88.1	87.0	5.5	2.0	2.2	0.811	188
11	15	180L	3H18L893CT000	725	22.7	14.8	0.76	0.70	0.60	0.60	88.6	88.6	87.5	5.5	2.0	2.2	0.906	203
15	20	200L	3H20L853CT000	725	28.4	20.2	0.82	0.77	0.65	0.65	89.6	89.6	88.6	6.0	2.3	2.5	1.44	271
18.5	25	225S	3H22S823CT000	725	34.8	24.9	0.82	0.80	0.72	0.72	90.1	90.1	89.1	5.5	2.0	2.2	2.11	324
22	30	225M	3H22M833CT000	725	41.2	29.6	0.82	0.80	0.72	0.72	90.6	90.6	89.6	5.5	2.0	2.2	2.41	351
30	40	250M	3H25M813CT000	730	55.7	40.0	0.82	0.80	0.72	0.72	91.3	91.3	91.0	5.5	2.0	2.2	3.25	498
37	50	280S	3H28S823CT000	730	71.9	49.4	0.78	0.74	0.65	0.65	91.8	91.8	91.0	5.5	2.0	2.2	6.18	641
45	60	280M	3H28M853CT000	738	89.3	59.4	0.76	0.72	0.60	0.60	92.2	92.2	91.5	5.5	2.0	2.2	7.25	690

Note: All performance values are subject to tolerance as per IS/IEC 60034-1

DIMENSIONAL DRAWING: IE3 EFFICIENCY SERIES FOR SAFE AREA APPLICATION FOOT MOUNTED (B3) MOTORS

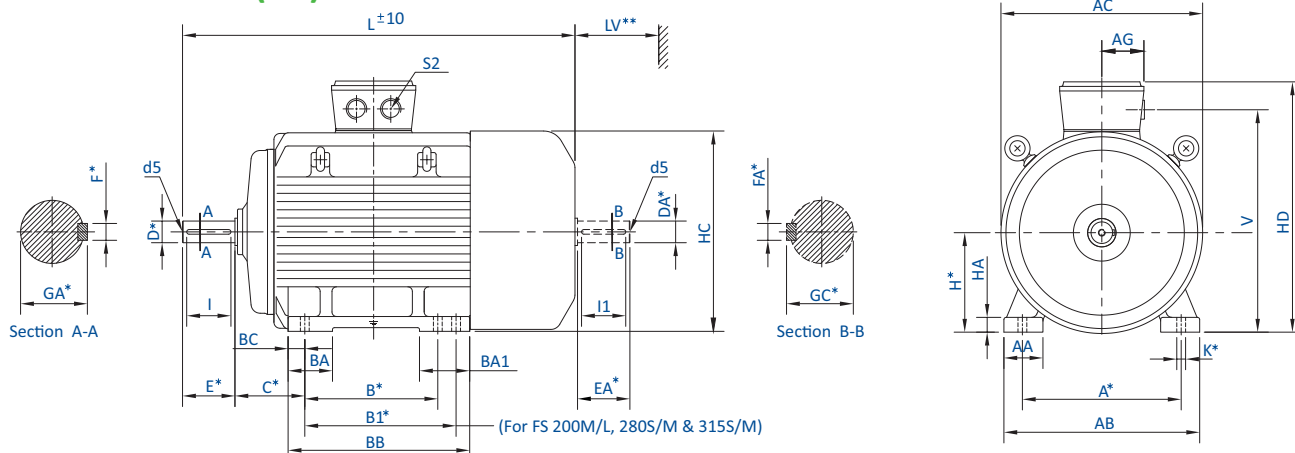

IEC Fr. Size	Pole	FIXING						GENERAL										TERMINAL BOX				SHAFT						
		A*	B*	B1*	C*	H*	K*	AB	BB	AA	BA	BA1	BC	HA	HC	HD	L	LV**	AC	V	AG	S2 BSC	D* DA*	E* EA*	F* FA*	GA* GC*	I I1	d5
63	2	100	80	—	40	63	7	126	100	28	30	—	10	7	125	179	206	30	124	149	40	1x3/4"	11	23	4	12.5	18	M4
71	2(0.37kW),4(0.25kW),8(0.12kW)	112	90	—	45	71	7	135	110	31	30	—	10	7	141	195	235	30	140	166	40	1x3/4"	14	30	5	16	25	M5
	2(0.55kW),4(0.37kW)	269																										
80	2&4	125	100	—	50	80	10	150	124	32	36	—	12	9	168	220	292	30	174	191	40	1x3/4"	19	40	6	21.5	35	M6
90S	2,4&6	100	—	56	90	10	168	—	34	31.5	—	13	12	177	230	336	35	174	199	52	2x3/4"	24	50	8	27	45	M8	
	8															302												
90L	2,4&6	140	—	56	90	10	168	—	34	31.5	—	13	12	177	230	361	35	174	199	52	2x3/4"	24	50	8	27	45	M8	
	8															327												
100L	2&4	160	140	—	63	100	12	190	174	43.5	36	—	17	12	198	257	387	40	195	225	56	2x1"	28	60	8	31	55	M10
	6&8																366											
112M	4&6	190	140	—	70	112	12	220	174	47	36	—	17	12	222	282	419	45	220	246	56	2x1"	28	60	8	31	55	M10
	8																388											
132S	2	216	140	—	89	132	12	256	180	54	50	—	20	16	262	328	518	50	260	291	63	2x1"	38	80	10	41	70	M12
	4																475											
132M	6&8	178	—	89	132	12	256	180	54	50	—	20	16	262	328	459	50	260	291	63	2x1"	38	80	10	41	70	M12	
	4&6															556												
160M	2(9.3kW),4(9.3kW)&6	210	—	108	160	15	310	—	58	70	—	20	20	318	383	605	60	316	346	63	2x1"	42	110	12	45	105	M16	
	2(11kW)&4(11kW)															635												
	2(15kW)															654												
	8															585												
160L	2	254	—	108	160	15	310	—	58	70	—	20	20	318	383	697	60	316	346	63	2x1"	42	110	12	45	105	M16	
	4&6(11kW)															679												
	6															649												
	8															629												
180M	2,4&8	279	241	—	121	180	15	344	281	65	70	—	20	26	357	451	727	70	354	396	97	2x1 1/2"	48	110	14	51.5	100	M16
180L	4,6&8	279	279	—	121	180	15	344	319	65	70	—	20	26	357	451	765	70	354	396	97	2x1 1/2"	48	110	14	51.5	100	M16
200M/L	2,4&6	318	267	305	133	200	19	398	355	85	85	—	25	32	419	536	803	80	438	468	155	2x1 1/4"	55	110	16	59	100	M20
200L	8	318	305	—	133	200	19	398	355	85	85	—	25	32	397	519	772	80	394	449	155	2x2"	55	110	16	59	100	M20
225S	4	286	—	149	225	19	436	—	85	85	—	25	34	450	568	872	90	445	500	155	2x2"	60	140	18	64	130	M20	
	8															827												
225M	2	356	—	149	225	19	436	—	85	85	—	25	34	450	568	867	90	445	500	155	2x2"	55	110	16	59	100	M20	
	4&6															897												
250M	8	311	—	149	225	19	436	—	85	85	—	25	34	450	568	855	90	445	500	155	2x2"	60	140	18	64	130	M20	
	2															914												
280S/M	2	406	349	—	168	250	24	506	425	100	115	—	46	42	495	665	993	100	489	578	243	2x2"	60	140	18	64	130	M20
	4,6&8																914											
315S/M	2	406	457	—	216	315	28	625	540	120	120	—	43	45	617	834	1175	130	604	728	278	2x2"	65	140	18	69	130	M20
	4&6																1167											
315L	2	508	—	216	315	28	625	593	120	120	—	43	45	617	834	1342	130	604	728	278	2x2 1/2"	65	140	18	69	130	M20	
	4&6															1332												
355L	2	610	630	—	254	355	28	710	770	110	170	—	70	45	703	939	1461	145	695	850	403	2x3"	75	140	20	79.5	130	M20
	2(280kW)																1505											
	4&6																1531											
	4(315kW),6(250kW)																1575											

- Notes:**
- * This is a mandatory dimension for all standard motors
 - **Minimum distance for efficient cooling of motor to be maintained by user
 - 1. All dimensions are in mm unless otherwise specified
 - 2. Tolerances on mandatory dimensions are as per IS:1231
 - 3. For non standard motors, dimensions may change. Please contact sales office for details
1. Eyebolt is not provided for frame sizes from 63 to 90 frame
 2. Shaft extension at NDE identical to standard shaft extension at DE is not possible in 4, 6 & 8 pole in frames 315L & 355L
 3. TB Position: To be read as: when viewed from DE side / when viewed parallel to the shaft / cable entry
(a) 63, 160 to 225 Frame: Top / Center of body / RHS when viewed from DE side
(b) 71 to 132 Frame & 250 to 355 Frame: Top / Towards Drive End / RHS when viewed from DE side

DIMENSIONAL DRAWING: IE3 EFFICIENCY SERIES FOR SAFE AREA APPLICATION FLANGE MOUNTED (B5) MOTORS

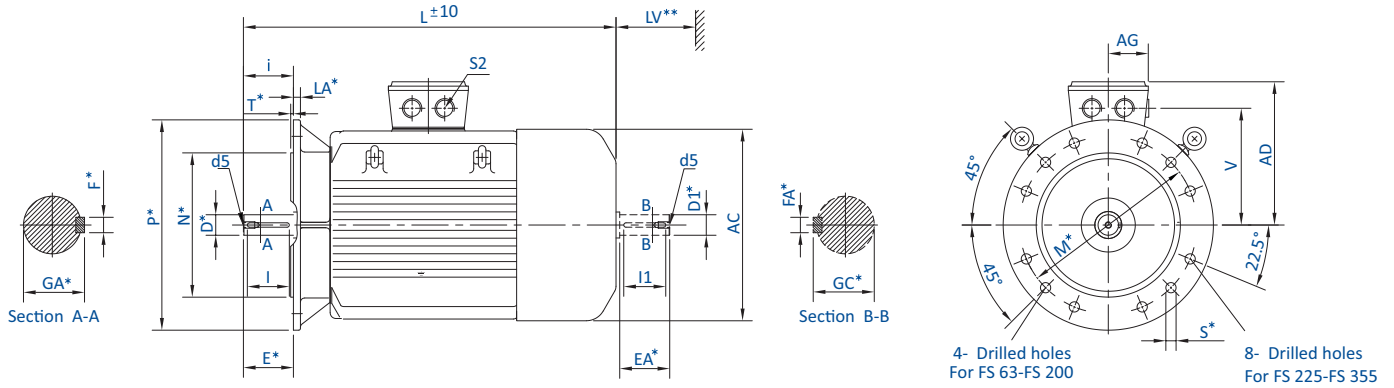

IEC Fr. Size	Pole	FIXING					GENERAL						TERMINAL BOX			SHAFT					
		p*	N*	M*	i	S*	T*	LA*	AD	L	LV**	AC	V	AG	S2 BSC	D* DA*	E* EA*	F* FA*	GA* GC*	I I1	d5
63	2	140	95	115	23	10	3	9	116	225	30	124	86	40	1x3/4"	11	23	4	12.5	18	M4
71	2(0.37kW),4(0.25kW),8(0.12kW)	160	110	130	30	10	3.5	9	124	262	30	140	95	40	1x3/4"	14	30	5	16	25	M5
	296																				
80	2&4	200	130	165	40	12	3.5	10	140	292	30	174	111	40	1x3/4"	19	40	6	21.5	35	M6
90S	2,4&6	200	130	165	50	12	3.5	10	140	336	35	174	109	52	2x3/4"	24	50	8	27	45	M8
	302																				
90L	2,4&6	200	130	165	50	12	3.5	10	140	361	35	174	109	52	2x3/4"	24	50	8	27	45	M8
	327																				
100L	2&4	250	180	215	60	15	4	11	157	387	40	195	125	56	2x1"	28	60	8	31	55	M10
	366																				
112M	4&6	250	180	215	60	15	4	11	170	419	45	220	134	56	2x1"	28	60	8	31	55	M10
	388																				
132S	2	300	230	265	80	15	4	12	196	518	50	260	159	63	2x1"	38	80	10	41	70	M12
	4									475											
	6&8									459											
132M	4&6	350	250	300	110	19	5	13	220	556	60	316	186	63	2x1"	42	110	12	45	105	M16
	605																				
160M	2(9.3kW),4(9.3kW)&6	350	250	300	110	19	5	13	220	635	60	316	186	63	2x1"	42	110	12	45	105	M16
	2(11kW)&4(11kW)									654											
	2(15kW)									585											
	8									697											
160L	2	350	250	300	110	19	5	13	220	679	60	316	186	63	2x1"	42	110	12	45	105	M16
	4&6(11kW)									649											
	6									629											
	8									727											
180M	2,4&8	350	250	300	110	19	5	13	271	765	70	354	216	97	2x1 1/2"	48	110	14	51.5	100	M16
	2,6&8									803											
200M/L	2,4&6	400	300	350	110	19	5	15	336	803	80	438	268	155	2x1 1/4"	55	110	16	59	100	M20
	8								319	772											
200L	4	400	300	350	110	19	5	15	872	803	80	438	268	155	2x2"	55	110	16	59	100	M20
	8								827												
225S	2	450	350	400	110	19	5	16	343	867	90	445	275	155	2x2"	55	110	16	59	100	M20
	8									855											
225M	4&6	450	350	400	110	19	5	16	343	897	90	445	275	155	2x2"	55	110	16	59	100	M20
	8									914											
250M	2	550	450	500	140	19	5	18	415	993	100	489	328	243	2x2"	60	140	18	64	130	M20
	4,6&8									914											
280S/M	2	550	450	500	140	19	5	18	445	1010	115	544	358	243	2x2"	65	140	18	69	130	M20
	4,6&8									1175											
315S/M	2	660	550	600	140	24	6	22	519	1167	130	604	413	278	2x2"	65	140	18	69	130	M20
	4&6									1342											
315L	2	660	550	600	140	24	6	22	519	1332	130	604	413	278	2x2 1/2"	65	140	18	69	130	M24
	4&6									1461											
355L	2	800	680	740	140	24	6	25	584	1505	145	695	495	403	2x3"	75	140	20	79.5	130	M20
	2(280kW)									1531											
	4&6									1575											
	4(315kW),6(250kW)	800	680	740	140	210				1575	145	695	495	403	2x3"	100	210	28	106	200	M24

Notes: * This is a mandatory dimension for all standard motors
 **Minimum distance for efficient cooling of motor to be maintained by user
 1. All dimensions are in mm unless otherwise specified
 2. Tolerances on mandatory dimensions are as per IS:2223
 3. For non standard motors, dimensions may change. Please contact sales office for details

Notes: 1. Eyebolt is not provided for frame sizes from 63 to 90 frame
 2. Shaft extension at NDE identical to standard shaft extension at DE is not possible in 4, 6 & 8 pole in frames 315L & 355L
 3. TB Position: To be read as: when viewed parallel to the shaft / cable entry
(a) 63, 160 to 225 Frame: Center of body / RHS when viewed from DE side & TB is at Top
(b) 71 to 132 Frame & 250 to 355 Frame: Towards Drive End / RHS when viewed from DE side & TB is at Top

DIMENSIONAL DRAWING: IE3 EFFICIENCY SERIES FOR SAFE AREA APPLICATION FACE MOUNTED (B14) MOTORS

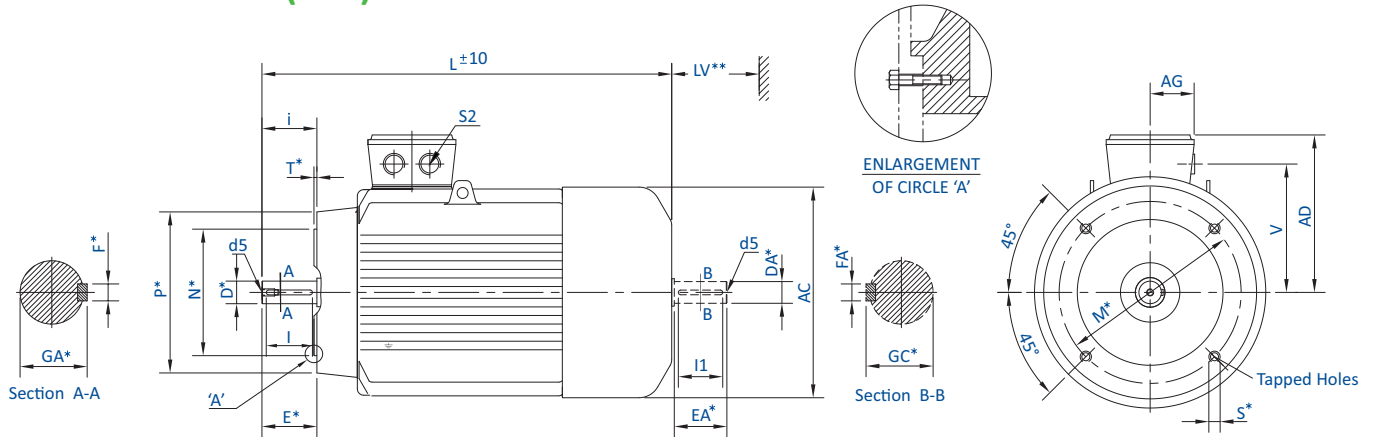

IEC Fr. Size	Pole	FIXING					GENERAL					TERMINAL BOX			SHAFT					
		p*	N*	M*	i	S*	T*	AD	L	LV**	AC	V	AG	S2 BSC	D* DA*	E* EA*	F* FA*	GA* GC*	I I1	d5
63	2	90	60	75	23	M5X10	2.5	116	206	30	124	86	40	1x3/4"	11	23	4	12.5	18	M4
71	2(0.37kW),4(0.25kW),8(0.12kW) 2(0.55kW),4(0.37kW)	105	70	85	30	M6X10	2.5	124	235	30	140	95	40	1x3/4"	14	30	5	16	25	M5
									269											
90S	2,4&6	140	95	115	50	M8X12	3	140	336	35	174	109	52	2x3/4"	24	50	8	27	45	M8
	8																			
90L	2,4&6	140	95	115	50	M8X12	3	140	361	35	174	109	52	2x3/4"	24	50	8	27	45	M8
	8																			
100L	2&4	160	110	130	60	M8X12	3.5	157	387	40	195	125	56	2x1"	28	60	8	31	55	M10
	6&8																			
112M	4&6	160	110	130	60	M8X12	3.5	170	419	45	220	134	56	2x1"	28	60	8	31	55	M10
	8																			

Notes:

- * This is a mandatory dimension for all standard motors
- **Minimum distance for efficient cooling of motor to be maintained by user
- 1. All dimensions are in mm unless otherwise specified
- 2. Tolerances on mandatory dimensions are as per IS: 2223
- 3. For non standard motors, dimensions may change. Please contact sales office for details

Notes:

1. Eyebolt is not provided in motors of 63 to 90 frame
2. For the dimensional drawing of 132 frame, B14 mounting, kindly contact our nearest sales office
3. TB Position: To be read as: when viewed from DE side / when viewed parallel to the shaft / cable entry

(a) 63 Frame: Top / Center of body / RHS when viewed from DE side
 (b) 71, 90 to 112 Frame: Top / Towards Drive End / RHS when viewed from DE side



Raw Material Warehouse



Motor Assembly

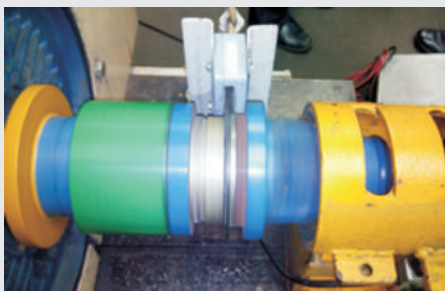

Torque Transducer



Large Motor Test Facility

LV MOTORS PRODUCT RANGE

Motors Conform to relevant Indian Standards (IS) & IEC 60034 series
Voltage: 415V +/- 10%, Frequency: 50 Hz +/- 5%, Combined Variation: +/- 10%

Insulation: Class 'F' with temperature rise limited to Class 'B', Rotation: Bi-directional
Cooling: IC411, Degree of Protection: IP55, Altitude: upto 1000m above MSL

Motor Type	Frame	Power (kW)	Polarity		Standard Technical Specifications	Optional Features	Applications	
IE2 Motors IE3 Motors Large LT Motors (DCCA)	71 to 355 80 to 355 355 to 450	0.37 to 355 0.55 to 355 250 to 1250	2, 4, 6 2, 4, 6 2, 4, 6, 8		<ul style="list-style-type: none"> Ambient: 50° C Ambient for DCCA: 40° C Mounting: B3, B5, B35, V1 Inverter Grade Winding: For IE3 and DCCA Duty: S1 RTD & BTD: For DCCA motors 	<ul style="list-style-type: none"> Non Standard Voltage: upto 690V Shaft Material: EN24 Enclosure: IP56 / 65 / 66 Forced Cooling: 132 to 450 Frame Space Heater: 90 Frame onwards Roller Bearing: 160 Frame onwards RTD & BTD: 250 Frame onwards Insulation: Class H Thermistor: 80 to 355L 	<ul style="list-style-type: none"> Insulated Bearing: 160 Frame onwards High Temperature Grease: Suitable up to 200° C Higher Polarity on request SS Hardware Non std shaft diameter / extension (subject to confirmation) Non Standard Paint Provision for Encoder Mounting Low Vibration as per IS or IEC 	Most common applications comprising of: Pump, Fan, Compressor, Packing Machinery, Coiler/De-coiler, Agro Equipment, Food Processing Equipment, Paper Machinery, Agitator, Dairy Equipment, Machine Tool, Air Conditioning, Material Handling, Plastic Machinery, Textile Machinery, Cooling Tower, Crusher, Material Handling
IE4 MOTORS	112 to 225	1.5 to 45	4		<ul style="list-style-type: none"> Ambient: 50° C Mounting: B3, B5, B35, V1 Inverter Duty Winding Duty: S1 VPI: With Class H solvent less Resin 	<ul style="list-style-type: none"> Shaft Material: EN24 Enclosure: IP56 / 65 / 66 Roller Bearing: 160 Frame onwards Insulation: Class H Space Heater: 90 frame onwards Thermistor: 80 to 225 Frame 	<ul style="list-style-type: none"> Non std shaft diameter / extension (subject to confirmation) Non Standard Paint Provision for Encoder Mounting Low Vibration as per IS or IEC 	Fans, HVAC, Pumps, Textiles, hydraulic press
Standard Flame Proof Motors IE2 Flame Proof Motors IE3 Flame Proof Motors	80 to 315 80 to 315 80 to 315	0.37 to 200 0.37 to 200 0.75 to 180	2, 4, 6, 8 2, 4, 6, 8 2, 4, 6		<ul style="list-style-type: none"> Ambient: 45° C Mounting: B3, B5, B35, V1 Inverter Grade Winding: For IE3 Motors Duty: S1 	<ul style="list-style-type: none"> Non Standard Voltage: 550V Shaft Material: EN24 Enclosure: IP56 / 65 / 66 Space Heater: 90 Frame onwards Roller Bearing: 160 Frame onwards Insulation: Class H 8 pole motor on request Thermistor: 80 to 315 L 	<ul style="list-style-type: none"> Insulated Bearing: 160 Frame onwards Intermittent Duty S3, S4: 80 to 132 Frame in 4 pole only Non std shaft diameter / extension Motors for Inverter Duty Test facility for combined Testing with VFD Non Standard Paint Low Vibration as per IS or IEC 	Most common applications comprising of: Pump, Fan, Compressor, Material Handling, Agitator, LPG Bottling Plant, Pharma Machinery, Chemical Plant Machinery, Machinery for mines
IE2 Non - Sparking Motors	71 to 355	0.37 to 355	2, 4, 6		<ul style="list-style-type: none"> Ambient: 50° C Mounting: B3, B5, B35, V1 (B14 upto 132 Frame) Duty: S1 	<ul style="list-style-type: none"> Shaft Material: EN24 Enclosure: IP56 / 65 / 66 Roller Bearing: 160 Frame onwards Insulation: Class H 	<ul style="list-style-type: none"> Insulated Bearing: 160 Frame onwards Higher Polarity on request Non std shaft diameter / extension Motors for Inverter Duty Test facility for combined testing with VFD Non Standard Paint Low Vibration as per IS or IEC 	Pump, Fan, Compressor, Material Handling, Agitator, Pharma Machinery
Crane & Hoist Duty Motors	71 to 355	0.37 to 400	4, 6, 8		<ul style="list-style-type: none"> Ambient: 45° C Mounting: B3, B5, B35, V1 (B14 upto 132 Frame) Duty: S2, S3, S4, S5 Offered in DOL & Converter Fed Supply 	<ul style="list-style-type: none"> Non Standard Voltage: 380 to 460V Shaft Material: EN24 Enclosure: IP56 / 65 / 66 Space Heater: 90 Frame onwards Roller Bearing: 160 Frame onwards BTD: 250 Frame & above Insulation: Class H Thermistor: 80 to 355 L 	<ul style="list-style-type: none"> Insulated Bearing: 160 Frame onwards Non std shaft diameter & extension Motors for Inverter Duty Non Standard Paint Low Vibration as per IS or IEC 	Crane, Hoist, Lift, Material Handling, Car Stacker, Door Opening
Brake Motors (With Integral DC Brake)	71 to 132	0.37 to 9.3	2, 4, 6, 8		<ul style="list-style-type: none"> Ambient: 50° C Duty: S1, S2, S3, S4, S5 Mounting: B3, B5, B35 Integral DC Brake 	<ul style="list-style-type: none"> Non Standard Voltage: upto 460V Manual Release Arrangement: For 90 to 132 Frame Motors for Inverter Duty 	<ul style="list-style-type: none"> Non std shaft diameter & extension Double Shaft Extension for brake arrangement Non Standard Paint 	Crane, Hoist, Material Handling, Textile, Pharma to name a few
Brake Motors (With External Mounted Brake)	71 to 200	0.37 to 22	2, 4, 6		<ul style="list-style-type: none"> Ambient: 50° C Duty: S1, S2, S3, S4, S5 Mounting: B3, B5, B35 External Mounted DC Brake/Arrangement 	<ul style="list-style-type: none"> Non Standard Voltage: upto 460V Manual Release Arrangement Motors for Inverter Duty 	<ul style="list-style-type: none"> Double Shaft Extension for brake arrangement Non Standard Paint Higher Braking Torque 	Crane, Hoist, Material Handling, Textile, Pharma to name a few
Slip Ring Motors	100 to 160	1.1 to 10	4, 6		<ul style="list-style-type: none"> Ambient: 45° C Mounting: B3, B5, B35 Duty: S3, S4, S5 	<ul style="list-style-type: none"> Non std shaft diameter & extension 	<ul style="list-style-type: none"> Non Standard Paint 	Crane, Hoist, Lift, Material Handling
Textile Motors	100 to 160	1.1 to 15	4, 6, 8		<ul style="list-style-type: none"> Ambient: 50° C Mounting: B3, B5, B35 Duty: S1 	<ul style="list-style-type: none"> Non Standard Voltage: upto 500V Insulation: Class H 	<ul style="list-style-type: none"> Motors for Inverter Duty Non Standard Paint Low Vibration as per IS 	Ginning, Textile Machinery
Cane Unloader Motors	160 to 225	11 to 30	6		<ul style="list-style-type: none"> Ambient: 45° C Start/Stop per Hour: upto 900 Mounting: B3, B5, B35 Forced Cooling Thermostat Duty: S5, 50% CDF Shaft Material: EN24 	<ul style="list-style-type: none"> Insulation: Class H Thermistor 	<ul style="list-style-type: none"> Insulated Bearing: 160 Frame onwards Non Standard Paint 	Cane Loading-Unloading Machine

CERTIFICATIONS



Super Premium Energy Efficient
SynchroVERT™ IE4 Motor:
**Winner of CII's Most Innovative
 Energy Saving Product 2016**

New Product



Ultra Premium Energy Efficient
 IE5 Motor:
**Winner of CII's Most Innovative
 Energy Saving Product 2018**

Upcoming Product

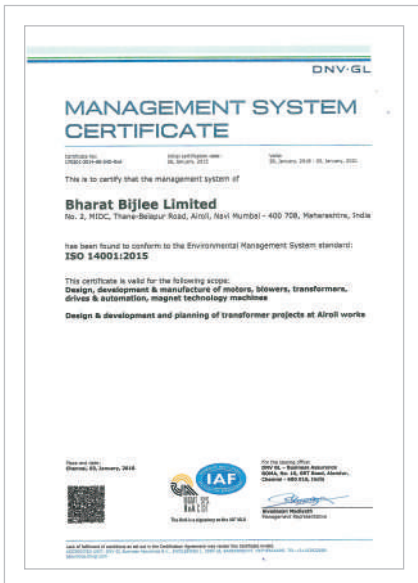

ISO 14001:2015



ISO 45001:2018



ISO 9001:2015

MOTOR, DRIVE AND AUTOMATION SOLUTIONS



Visualisation & HMI



Controls



Drives

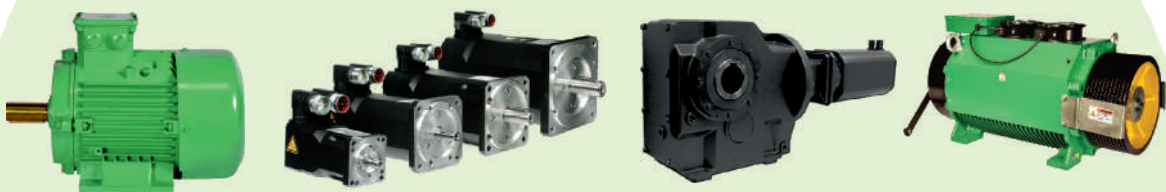

Motors

Bharat Bijlee's Industrial Systems product portfolio caters to a spectrum of applications and spans the machine automation pyramid.

A series of 30 horizontal green lines spaced evenly down the page, providing a template for writing.

ALL INDIA SERVICE NETWORK

- Regional Offices
- 🔥 Works
- Authorised Service Centre: Motors
- ✂ Service Centre: Servo Motors



REGIONAL OFFICES

- Mumbai:** +91 22 6145 7200
- Pune:** 7410011272 / 7410011271
- Ahmedabad:** +91 79 66049200 / 9201
- New Delhi:** +91 11 2581 6931 / 6932 / 6933
- Indore:** +91 731 2524 474 / 2514 486
- Ludhiana:** +91 161 2775 692 / 93
- Jaipur:** +91 141 2377 223
- Kolkata:** +91 33 2443 2368 / 2382 / 2383
- Bengaluru:** +91 80 2559 2646 / 2137 / 2681
- Chennai:** +91 44 2815 4794 / 4793
- Secunderabad:** +91 40 2780 1791 / 2781 4512
- Coimbatore:** +91 422 4204314

For any enquiries please write to motorlvsales@bharatbijlee.com

BB ServiceLINE™ +91 22 - 2763 7290 | serviceline@bharatbijlee.com
 Customer Service Helpdesk for Industrial Systems

Bharat Bijlee
REGISTERED OFFICE
 Electric Mansion, 6th Floor,
 Appasaheb Marathe Marg,
 Prabhadevi, Mumbai 400 025
 T: +91 22 2430 6237 / 6375
 E: info@bharatbijlee.com
 CIN: L31300MH1946PLC005017

WORKS
 No. 2, MIDC Thane-Belapur Road, Airoli,
 Navi Mumbai 400 708
 T: +91 22 2763 7200 / +91 22 2760 0401
www.bharatbijlee.com

Product improvement is a continuous process and technical information herein is subject to change. Please contact our nearest sales office for the latest information.